

⚠ WARNING

- Read and follow all instructions carefully.
- Disconnect and lock-out power before installation and maintenance. Working on or near energized equipment can result in severe injury or death.
- Do not operate equipment without guards in place. Exposed equipment can result in severe injury or death.

⚠ CAUTION

- Periodic inspections should be performed. Failure to perform proper maintenance can result in premature product failure and personal injury.

These instructions cover single and double locking collar tapered roller bearings. It is important that they be read in their entirety before attempting installation or removal. The procedures indicated should be carefully followed. Failure to do so can result in misinstallation which could cause bearing performance problems as well as serious personal injury.

NOTICE:

- The bearing is designed for a maximum permissible static misalignment of ± 3 degrees. Installation, handling or operation of the bearing in excess of the maximum of ± 3 degrees can cause reduction in bearing performance and may lead to equipment failure.
- Do not strike on or hammer on any component of the bearing and/or shaft. Impact can result in damage to the bearing that may cause reduction in bearing performance and may lead to equipment failure.



BEARINGS IN BOLT-ON HOUSINGS

Step 1: Inspect Shaft and Bore

Shaft should be within tolerance range shown in Table 1, clean and free of nicks and burrs. Mount bearings on unused section of shafting or repair/replace shafting as required. Inspect both the shaft and bearing bore for debris or contaminants. Wipe clean as necessary.

TABLE 1

RECOMMENDED SHAFT TOLERANCES	
NOMINAL BORE DIAMETER	TOLERANCE (INCH)
1 3/16 - 2	+0.000 / -0.0005
2 3/16 - 4	+0.000 / -0.0010
4 7/16 - 5	+0.000 / -0.0015

Step 2: Check Support Surfaces

Make sure the base of the housing and the support surfaces are clean and free from burrs. If the housing elevation is adjusted with shims these must cover the entire contact area between the housing and the support surface.

Step 3: Install Unit

To aid installation, keep weight off bearing during mounting. Slide unit onto shaft by pushing on the inner ring. If it is difficult to mount bearing on shaft, use a piece of emery cloth to reduce any high spots on the shaft.

Expansion Bearing Applications:

For most applications using expansion type units, the fixed unit (non-expansion unit) is placed at the drive end of the shaft. The expansion unit would be placed where relative movement can be best tolerated.

Step 4: Fasten Unit in Place

Install housing mounting bolts and check bearing alignment. Align the bearing units as closely as possible. Tighten mounting bolts to recommended fastener torques. Check the shaft for freedom of rotation by rotating shaft with hand in both directions.

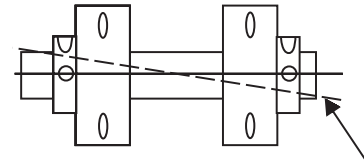

Step 5: Position Insert

If expansion units are used, the insert must be located in the housing to allow for axial shaft expansion and/or contraction. In most applications, position the bearing insert within the housing towards the fixed (non-expansion) unit. It may be necessary to unload the bearing while moving the assembly.

Use Table 2 to review the total available bearing expansion. If the application requires additional expansion, contact application engineering.

TABLE 2

TOTAL AVAILABLE PILLOW BLOCK HOUSING EXPANSION			
BORE SIZE		EXPANSION	
inch	mm	inch	mm
1 3/16 - 2 3/16	35 - 55	3/16	4.76
2 1/4 - 2 1/2	60 - 65	1/4	6.35
2 11/16 - 3 1/2	70 - 95	5/16	7.94
3 15/16 - 5	100 - 125	3/8	9.53

BEARINGS IN BOLT-ON HOUSINGS - CONTINUED

Step 6: Tighten Locking Mechanism

Setscrew Locking Inserts (single lock and double lock)

- Setscrews in multiple bearing applications should be aligned as shown below.
- Tighten the first screw to one half the recommended torque in table 3. Tightened second screw to full torque. Tighten first screw to full torque.
- If the bearing unit has two lock collar, repeat the same procedure for the second setscrews. Check shaft again freedom of rotation and then tighten the second bearing unit in the same fashion.
- When all bearings are tightened, perform a final check to the shaft for freedom of rotation.

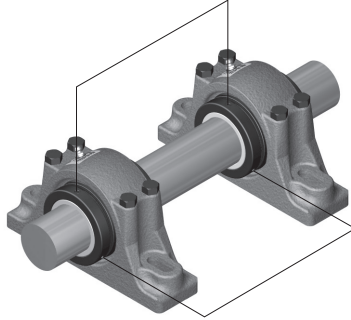

REPLACING EXISTING BEARING INSERTS

Step 1: Remove Cap Bolts and Top Half of Housing

Do not mix housing top and bottom halves

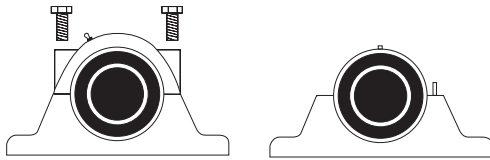

Step 2: Remove Bearing from Shaft

Loosen the setscrews and slide the bearing off the shaft

Step 3: Inspect Shaft and Housing Bore

Shaft should be within tolerance range shown in table 1 and free of nicks and burs, repair or replace shafting as needed. Inspect the housing for damage, wipe housing bore clean as necessary and check that the lubrication hole is clean and free of debris.

Step 4: Load New Insert and Tighten Housing

- Slide bearing onto shaft and seat the bearing in the housing base.
- Check to assure that the rubber grommet is properly seated in the lube hole in the top of the housing. Position the insert so that the lock pin lines up with the lock pin slot in the top half of the housing. Be sure that the lock pin is not positioned in the lube hole. Be sure to check the bearing inserts for proper alignment. Align the bearing within the housing.
- Install the top half of the housing. Tighten down the cap mounting bolts to the recommended torque listed in tables 4, 5, 6 or 7 based on the housing type.
- If insert can be made to swivel within housing by hand, fit is too loose and entire unit should be replaced. If heavy force is required, fit is too tight and entire unit should be replaced.

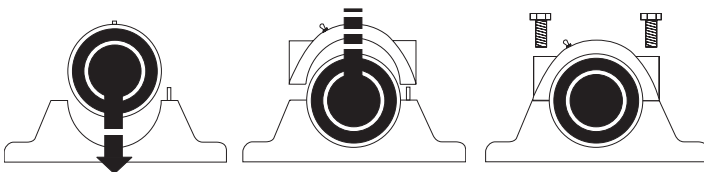

Step 5: Position Insert and Tighten Locking Mechanism

Refer to Steps 5 and 6 From Preceding Section

TABLE 3

LOCK COLLAR SETSCREW TORQUE			
BORE SIZE		HEX SIZE	FOOT-POUNDS
INCH	MM		
1 3/16 - 1 11/16	35 - 40	5/32	12
1 3/4 - 2 1/2	45 - 65	3/16	19
2 11/16 - 3 1/2	70 - 95	1/4	43
3 15/16 - 4	100 - 105	5/16	83
4 7/16 - 5	110 - 125	3/8	155

TABLE 4

PILLOW BLOCK HOUSING		
BORE SIZE		HOUSING CAP TIGHTENING TORQUE (FOOT-POUNDS)
INCH	MM	
1 3/16 - 1 1/4	-	17
1 3/8 - 2 3/16	35 - 55	30
2 1/4 - 3	60 - 75	75
3 3/16 - 4 1/2	80 - 115	265
4 15/16 - 5	120 - 125	390

TABLE 5

FLANGE BEARING HOUSING		
BORE SIZE		HOUSING CAP TIGHTENING TORQUE (FOOT-POUNDS)
INCH	MM	
1 3/16 - 2	35 - 50	30
2 3/16 - 3	55 - 75	75
3 3/16 - 4	80 - 105	150

TABLE 6

PILOTED FLANGE HOUSING			
BORE SIZE		OUTSIDE BOLTS TIGHTENING TORQUE (FOOT-POUNDS)	INSIDE BOLTS TIGHTENING TORQUE (FOOT-POUNDS)
INCH	MM		
1 3/16 - 2	35 - 50	17	4
2 3/16 - 3	55 - 75	50	8
3 3/16 - 4	80 - 105	75	17
4 7/16 - 5	110 - 125	150	75

TABLE 7

EXPANSION PILLOW BLOCK HOUSING		
BORE SIZE		HOUSING CAP TIGHTENING TORQUE (FOOT-POUNDS)
INCH	MM	
1 3/16 - 1 1/4	-	17
1 3/4 - 2 3/16	35 - 55	30
2 1/4 - 3	60 - 75	75
3 3/16 - 3 1/2	80 - 95	265
3 15/16 - 4 1/2	100 - 115	150
4 15/16 - 5	120 - 125	265

PRE-MOUNTING CHECKLIST:

All Sealmaster RPB Mounted Tapered Roller Bearings are delivered with a high quality lithium complex grease with an EP additive. The bearing is ready for use with no initial lubrication required. The grease consists of a lithium complex thickener, mineral oil, and NLGI grade 2 consistency.

Compatibility of grease is critical; therefore consult with Application Engineering and your grease supplier to insure greases are compatible. For best performance it is recommended to relubricate with lithium complex thickened grease with a comparable NLGI consistency and base oil properties.

Relubricatable Sealmaster bearings are supplied with grease fittings or zerks for ease of lubrication with hand or automatic grease guns. Always wipe the fitting and grease nozzle clean.

CAUTION:

If possible, it is recommended to lubricate the bearing while rotating, until grease purge is observed from the seals. If this is not an option due to safety reasons, follow the alternate lubrication procedure below.

ALTERNATE LUBRICATION PROCEDURE:

Stop rotating equipment. Add one half the recommended amount shown in Table 8. Start the bearing and run for a few minutes. Stop the bearing and add the second half of the recommended amount. A temperature rise after lubrication, sometimes 30°F (17°C), is normal. Bearing should operate at temperatures less than 200°F (94°C) and should not exceed 250° (121°C) for intermittent operation. For lubrication guidelines, see Tables 9.

NOTE: Grease charges in Table 8 are based on the use of lithium complex thickened grease with a NLGI grade 2 consistency.

NOTE: Table 9 are general recommendations. Experience and testing may be required for specific applications.

TABLE 8

GREASE CHARGE FOR RELUBRICATION		
BORE SIZE		GREASE CHARGE (MASS - OUNCES)
INCH	MM	
1 3/16 - 1 1/4	-	0.10
1 3/8 - 1 7/16	35	0.20
1 1/2 - 1 11/16	40	0.30
1 3/4 - 2	45 - 50	0.50
2 3/16	55	0.55
2 1/4 - 2 1/2	60 - 65	0.65
2 11/16 - 3	70 - 75	0.85
3 3/16 - 3 1/2	80 - 95	1.25
3 15/16 - 4	100 - 105	2.50
4 7/16 - 4 1/2	110 - 115	3.00
4 15/16 - 5	120 - 125	4.75

TABLE 9

RELUBRICATION RECOMMENDATIONS			
ENVIRONMENT	TEMPERATURE (°F)	SPEED (% CATALOG MAX)	HI SUFFIX
Dirty	-20 to 200	0 - 100%	Daily to 1 Week
		0 - 25%	4 to 10 Months
Clean	-20 to 125	26 - 50%	1 to 4 Months
		51 - 75%	1 Week to 1 Month
		76 - 100%	Daily to 1 Week
		0 - 25%	2 to 6 Weeks
	125 to 175	26 - 50%	1 Week to 1 Month
		51 - 75%	Daily to 1 Week
		76 - 100%	
	175 to 200	0 - 100%	Daily to 1 Week

TABLE 10

MAXIMUM OPERATIONAL SPEED		
BORE SIZE		SPEED (RPM)
INCH	MM	
1 3/16 - 1 1/4	-	4000
1 3/8 - 1 7/16	35	3500
1 1/2 - 1 11/16	40	3000
1 3/4 - 2 3/16	45 - 50	2500
2 1/4 - 2 1/2	60 - 65	2000
2 11/16 - 3	70 - 75	1750
3 3/16 - 3 1/2	80 - 95	1500
3 15/16 - 4 1/2	100 - 115	1250
4 15/16 - 5	120 - 125	1000

